

Figured dimensions only are to be taken from this drawing. All dimensions are to be checked on site before any work is put in hand. IF IN DOUBT ASK.

CDM: Hazard Elimination & Risk Reduction has been undertaken and recorded where appropriate, in accordance with the requirements of 'The Construction (Design and Management) Regulations 2015' and the associated 'Industry Guidance for Designers'



- Development site area - 3.812 Ha
- 3BSP Affordable Semi x 4
- 3BSP Private Semi x 10
- 4B7P Affordable detached x 5
- 4B7P Private detached x 10
- 5B10P Private detached x 6
- TOTAL 35

Parking Strategy - in curtilage parking to all units, 2 no. spaces each

Waste Management Strategy - kerbside collection to all properties. Bin uplift points provided within 25m for houses on 'non-adopted' roads in accordance with BS 5904 Waste Management in Buildings and within 15m of an adopted road.

Rev	Description	Date
D	SE update	08/05/24
C	SE update	09/05/24
B	Updated for altered flood area/SUDS	29/04/24
A	Updated layout from client discussion	19/03/24

COLIN ARMSTRONG ARCHITECTS
 Lyle House, Fairways Business Park, Inverness IV2 6AA
 T : 01463 712 288
 W : www.colinarmstrong.com



Client	AW Laing
Project	Housing Development Lettoch Road Nethybridge
Project No.	2104
Drawing No.	PL90-100
Revision	D
Site Layout	Proposed Site Layout - 35 units
Status	WIP
Date Created	Mar '24
Scale	1 : 500
Drawn by	MM
Sheet	@ A1

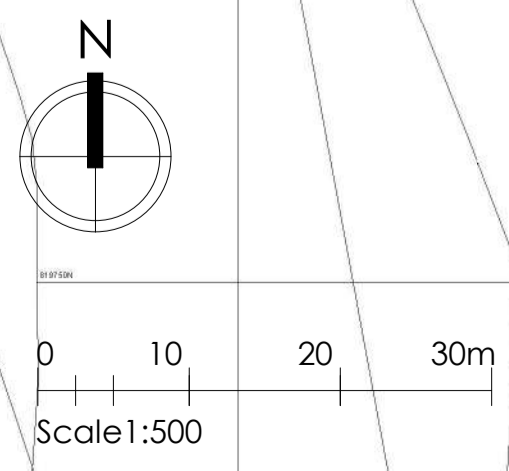

From file: X:\Documents\2104 - Lettoch Road for AW\100 - WORK - IN PROGRESS\3.1 BIM Models\3104-CA-RP-2023 - Site Model - Apr '24 - Revised.rvt
 Printed on: 08/05/2024 10:33:05